

RECOVERY IS THE SEED WE SOW, SOBRIETY WILL REDEEM US.  
LET IT GROW, SHARE OUR LIVES...

# "BETWEEN-US"

VOL. 19 ISSUE 2

FEBRUARY 2011

## Mail Call for All A. A.s at Home Or Abroad

February 1947  
Vol. 3 No. 9

A Newcomer Looks at A.A.

The past two evenings were spent in A.A. work, and tonight will find me doing the same. I should work on my novel or study; Henry Morgan is on the air and I'd like to listen to him, catch up on my reading and relax. There are many things I ought and should like to do.

Instead of the many things I think I'd like to do, it is far more important that I do the thing I KNOW I must do. Actually to me, 12th Step work is a self-ish part of our program. It helps me to practice sobriety. Each time I look upon some man or woman who is ill, frustrated and discouraged and in need of help, I humbly thank God for my sobriety. And, as my "charge" progresses, and health and confidence replace pallor and jitters, I am rewarded. This is but the beginning. Meeting a reunited family, hearing their words of gratitude and joy causes my soul to truly sing.

(*"Mail"* Continued on page 6)

<i>WHAT'S INSIDE</i>	<i>Page</i>
Office Financials	2
Secretary Meeting Notes	3
District Meetings/Corrections	4, 5
Club Info and Meetings	10, 11, 12
When & Where, Open Meetings	12, 13
Interesting Stuff	14 thru 20

## Anything Is Possible

September 1947  
Vol. 4, No. 4

I. Many of us are content, without question, to accept Alcoholics Anonymous for what it appears to be, namely, a fellowship of alcoholics which has had extraordinary success in releasing its members from the mortifying grip of alcoholism by assisting them to lead lives socially useful and spiritually rewarding. However, some systematic analysis of factors present in the problem with which this organization deals may serve to satisfy the intellectual curiosity of those inclined to philosophical or metaphysical speculation. Such an inquiry may also be of utility and significance in revealing the possibilities and the limitations of a therapy, fundamentally psychological and spiritual. The following outline, necessarily brief, is intended to be suggestive and not

(*"Possible"* Continued on page 7)

### Between-Us Subscribers!

New this month. Due to some strange and unique postal bulk mail pricing, it will be cheaper for us to mail the group subscription in two separate envelopes. Each envelope will contain three copies of the newsletter. This means that the group will receive six copies instead of five for the same low price of \$18.00.

Also, individual subscribers will receive three copies in their envelope. The price will remain the same, \$9.00. Share the extras with your friends.

Enjoy, and thanks for your support.



Published monthly by Greater Milwaukee Central Office, Inc., 7429 W. Greenfield Ave., West Allis, WI 53214, (414) 771-9119 Visit our website at: [www.aamilwaukee.com](http://www.aamilwaukee.com)

## Greater Milwaukee Central Office AA Profit & Loss December 2010

	<u>Dec 10</u>
<b>Ordinary Income/Expense</b>	
<b>Income</b>	
4000 - Literature Sales	16,435.59
4050 - Between us	925.00
4070 - Contributions	6,270.32
4080 - Gratitude boxes	8,088.70
4100 - Memorials	25.00
4150 - Other Income	270.25
4830 - Sales Discounts	10.00
48900 - Shipping and Delivery Income	368.92
<b>Total Income</b>	<u>32,393.78</u>
<b>Cost of Goods Sold</b>	
5000 - Literature	11,435.31
52900 - Purchases - Resale Items	85.73
<b>Total COGS</b>	<u>11,521.04</u>
<b>Gross Profit</b>	20,872.74
<b>Expense</b>	
59900 - POS Inventory Adjustments	19.90
6045 - Coffee/Soda Expense	299.37
6260 - Shipping and freight	251.74
6262 - Postage	9.62
6500 - Office	3,404.98
6600 - Payroll	9,874.97
6700 - Professional Fees	2,000.00
<b>Total Expense</b>	<u>15,860.58</u>
<b>Net Ordinary Income</b>	5,012.16
<b>Other Income/Expense</b>	
<b>Other Expense</b>	
Balancing Adjustments	0.00
<b>Total Other Expense</b>	<u>0.00</u>
<b>Net Other Income</b>	<u>0.00</u>
<b>Net Income</b>	<u><u>5,012.16</u></u>
CD Prudent Reserve	\$84,439.24
Money Market	24,184.79
Checking	2,021.00

### AREA 75 EVENTS CALENDAR

1. Go to Area 75 website at: [area75.org](http://area75.org), 2. Look for the Area 75 Events Calendar on the right side of the page. 3. Events listed are color coded according to the area office that listed them. 4. Click on the small down arrow at the top right hand corner of the Events listing for the color "key" to the area's events. 5. Click on the small down arrow in the middle (next to the date) to view a specific date or just use the scroll button to move up and down through the days listed.

## Secretary Meeting, January 11, 2011

Groups represented: 6, 7, 14, 15 TAL, 19 Step, 22, 23 Wed, 48, 51, 59, 60, 83, 89, 118, 200, 201, 232, A New Awakening, A New Day, Airport Gp, Another Chance Tuesday Night, Badger Group, Big Book Readers, Butler Sunday Night, By the Book, Daily Reprieve Men's, Dom 43 Daily Reflections, Each Day A New Beginning, Fire-side, Good Hope Sunday Night, Grupo Five Conceptos, Hales Corners Tuesday Night, Helping Hand, Honest and Able, How It Works, Keep Passing It On, LGBT Friendly, Mayflower, Milwaukee Gp, Monday Night Menomonee Falls Action, Monday Night Women's Waukesha, Muskego Saturday Night, New Beginnings Mukwonago, New Beginnings Oconomowoc, New Berlin Big Book Tue, New Berlin Friday, Oak Creek Friday (A P), Participation Gp, Pick-a-Topic, Primary Purpose Gp, Solutions Intergroup Friday and Sunday, Sun Afternoon Step/Topic, Sun Morning Big Book, Sun Morning Sunlight, Sunday Night Grapevine, Sunday Night Surrender, Sussex Friday Night Action, T-N-T, Traditions Meeting Open Disc, Wanderer's Gp, Waukesha Sunday Night, We Need Sanity, WELL Big Book, Willingness Gp. I'm sorry if I have missed anyone that was at the meeting.

Meeting opened by Jim B. at 7:00 p.m. Bank balances:  
Business Checking: \$2,021.00  
Money Market Savings: \$24, 184.79  
Prudent Reserve CD's: \$84,439.24

Time to return the Gratitude Boxes.

382 boxes have been returned with a total of \$14,196.65 to date. If you notice that your group hasn't returned the box...try to get it into the office as soon as possible.

Between-Us subscriptions: if your group hasn't paid yet for year 2011, now is the time. \$18.00 for 6 copies per month. Individual subscriptions are available at \$9.00 (3 copies).

41st Annual City Wide Jamboree for the Central Office will be held on Saturday September 17, 2011. Watch for more details.

Ken N. Area 75 Corrections Chair and 2011 Spring Conference Chair was the guest speaker. Call Ken at Diane at 414-543-8056 to volunteer for corrections work.

Meeting closed at 7:55 pm. Next meeting is Feb. 8, 2011. at 7p.m.

### Deaf, Deaf/Blind and Hard of Hearing AA Meeting List, ASL Interpreter available

- Thursdays at 8:00 p. St John Vianney Parish 1755 N. Calhoun Rd, Brookfield WI. **Open AA Meeting for everyone—Third Thursday of Month**, Wheelchair entrance available.

Meetings are weekly closed AA meetings, except where otherwise noted. All meetings are Non-Smoking. **ASL Interpreter available.**

Contact John R. through Voice Relay Service 800-973-8024 / 414-546-3246 TTY/Voice.

E-mail at: [jreskel@wi.rr.com](mailto:jreskel@wi.rr.com)

Contact George B. through Video Relay Service 866-327-8877 / 414-903-8905 TTY/VP

### AA Groups Need Your Support

- **Monday at 1:30 pm.**  
Bethesda Community Center  
2845 W Fond du Lac Ave  
Milwaukee, WI 53210

- **Thursday at 12:15 pm.**  
- **Wednesday 5:30 pm. Topic**  
both meet at  
St. John's Cathedral Complex,  
831 N. Van Buren St.  
Milwaukee, WI 53202

**Broken Arrow Gp.**  
- **Friday at 6:30 pm.**  
Serenity Club, 3677 E Pulaski  
Cudahy WI 53110

Perfect for a midday break, or a quick meeting before heading home. Get your meeting in early and relax.

# Orientation for GSR's

Second Tuesday of each month, 6:30 p.m. prior to the secretary's meeting, at the Milwaukee Central Office. Or, call Ken G. 608-221-2891, [sherwood1@charter.net](mailto:sherwood1@charter.net), to arrange for G.S.R. orientation at your district or workshop.

## DISTRICT MEETINGS

### DISTRICT

1. JACKSON, LaCROSSE, MONROE, TREMPLEAU & VERNON CNTY'S 2nd Sat. of month, 1:00 p.: Faith Evangelical Free Church, 6644 Hwy 16, Sparta WI 54656 (One mile west of Sparta)

2. GREEN LAKE & MARQUETTE CNTY'S & PART OF WAUSHARA CNTY 4th Sun. of month, 4:30 p., St. John's Church 1211 W. Main St., Princeton

3. MANITOWOC & SHEBOYGAN CNTY'S 3rd Wed. of month, 6:30 p., Even numbered months at 1907 Club, 2908 N. 21st St., Sheboygan. Odd numbered months: Alano Club, 404 S 29 St Manitowoc

4. MILWAUKEE CNTY (1 of 9) 2nd Thr. of month, 6:00 p., Alano Club, 1521 N. Prospect Av.

6. WALWORTH CNTY 2nd Wed. of month, 7:30 p., Walworth Alano Club, 611 E. Walworth St., Delavan

7. KENOSHA CNTY 3rd Sun. of month, 4:00 p., Kenosha Alano Club, 630 56th St.

8. ROCK CNTY (1 of 2) 1st Fri of month, 6:30 p., Good Shepard Lutheran Ch, 2447 Park St., Beloit

9. CRAWFORD, GRANT, IOWA and LAFAYETTE CNTY'S Last Mon. of month, 6:30 p., West View Methodist, Madison & Hathaway, Platteville,

10. Spanish District, at large. Contact Ernesto N. at 414 645-8591. Meets every Tue. at 5:00 p., 1663 S. 6th Street, Milw.

11. JEFFERSON CNTY Meets last Wed. at 5:30 p.m. Moravian Church, 301 College St., Lake Mills,

12. WASHINGTON CNTY 1st Wed. of month, 6:00 p., Jansen Family Park, Schuster Dr. West Bend

13. WAUKESHA CNTY (1 of 4) 1st Sun. of month, 4:00 p, St. Matthias Church, 111 E. Main, Waukesha

14. MILWAUKEE CNTY (1 of 9) 4th Wed. of month, 7:00 p, Milwaukee Central Office 7429 W Greenfield Ave., P.O. Box 13011, Wauwatosa WI 53226

15. MILWAUKEE CNTY (1 of 9) Last Sunday of month, 5:30 p, Milwaukee Room 933 E. Center St. Milwaukee

16. MILWAUKEE CNTY (1 of 9) 1st Wed. of month, 7:00 p, Faith United Methodist Church, 400 S. 91st St.,

17. RACINE CNTY (1 of 2) 3rd Sun. of month, 1:00 p, Grove Club, 1037 Grove Ave., Racine

18. Combined with District 2. See "District #2"

19/37. RICHLAND & SAUK CNTY'S Last Wed. of month, 6:15 p, in Rm 14, at Baraboo Civic Cntr.

20/21 DANE CNTY (1 of 2) Last Tue. of month, 6:30 p, Monona Community Center, 1011 Nichols Rd., 53716

22. MILWAUKEE CNTY (1 of 9) 2nd Thr of month, 6:00 p, Alano Club, 1521 N. Prospect Ave.

23. DODGE CNTY 1st Wed of month at 7:00 p, Dodge Cnty Alano Club, 115 N. Lincoln, Beaver Dam, call to confirm 920-583-3142

24. OZAUKEE CNTY 3rd Tue. of month, 6:30 p., Advent Lutheran, W63N642 Washington, Cedarburg

25. FOND du LAC CNTY 2nd Tue. of month, 6:30 p., Gratitude Club, 295 Ruggles St., Fond du Lac

26. DANE CNTY Combined with District 20

27. MILWAUKEE CNTY (1 of 9) 3rd Sat. of month, 9:00 a.m. 12 Step Club, 4102 W. Townsend

28. MILWAUKEE CNTY (1 of 9) 3rd Mon. of month, 7:00 p, Bay View United Methodist 2772 S Kinnickinnic Ave. Bay View, WI 53207

29. MILWAUKEE CNTY (1 of 9) 1st Mon. of month, 7:00 p, St. Alphonsus School, 6000 W. Loomis Rd., Greendale (enter west side/rear of school)

30. ROCK CNTY (1 of 2) 1st Fri. of month, 6:30 p. 734 Railroad St., Janesville. (Unity Group)

31. COLUMBIA CNTY 3rd Sun. of month, 6:30 p., Pardeeville Village Library, 119 N. Main St. Pardeeville, South entrance, lower level.

32/33. WAUKESHA CNTY (1 of 4) 3rd Sun. of month, 1:00 p, Galilee Lutheran Church, N24 W26430 Crestview Dr., Pewaukee.

34. WAUKESHA CNTY (1 of 4) 1st Tue. of month, 6:30 p, Northwest Alano Club, N88W17658 Christman Rd., Menomonee Falls

35. GREEN CNTY Quarterly, when called.

36. RACINE/KENOSHA (1 of 2) 2nd Tues. month 6:00 p.m., 12 & 12 Club, 724 N Pine St., Burlington

37. JUNEAU CNTY No information available.

**SEND ADDITIONS AND CORRECTIONS TO:**  
Greater Milwaukee Central Office  
7429 W. Greenfield Ave, West Allis, WI 53214,  
[dan@aamilwaukee.com](mailto:dan@aamilwaukee.com)

# CORRECTIONAL INSTITUTIONS

**ETHAN ALLEN SCHOOL, Wales, WI 53183**  
Open speaker meetings every Tuesday at 6:00 p.m. (no meeting on the 5th Tuesday of a month). Need facilitators and speakers for 2010, contact Mark G at 262-896-9526 [mgukich@wi.rr.com](mailto:mgukich@wi.rr.com) or Perry C. at 414-588-1638 [pgcristan@sbcglobal.net](mailto:pgcristan@sbcglobal.net)

**TAYCHEEDAH CORRECTIONAL**, Meetings are held every other Tuesday, 5:30 -7:30 p.m. Contact: Deb L-H. (920)238-7414

**FEDERAL CORRECTIONAL INSTITUTION**, P.O. Box 1085 Oxford, No Meeting!

**FEDERAL CORRECTIONAL Satellite Camp**, New Path Group, P. O. Box 1085 Oxford, WI. Meetings Wed. at 1:30 p.m.

**OAK HILL AA GROUP, OAK HILL WCI**  
5212 Hwy M, P.O. Box 140 Oregon, WI 53575 Meetings Wednesday at 7:00 p.m. and Sunday at 6:30 p.m. Contact: Rick B. (608) 235-5154

**THOMPSON FARM, RT. 2 DEERFIELD, WI.**  
Closed meeting Tuesday at 8:00 p.m. Contact: Tom Dickert, (608)764-5755

**SOUTHERN OAKS GIRLS SCHOOL, Union Grove WI**, AA Wednesday 5:55 p.m. and Alateen Tuesday 6:30 p.m. Contact: Marty S. (414) 975-8903 for clearance

**ROBERT ELLSWORTH CORRECTIONAL**, 21425A Spring St., Union Grove, 53182 AA Wed. 7:30 PM, AA Mon. night 6:00 p.m. and 7:00 p.m. and Wed, at 7:00 p.m. Contact Jo

(262) 551-7371 or Karelyn P. 414-327-7915.

**KETTLE MORAIN CORRECTIONAL**, Box 31, W9071 Forrest Dr., Plymouth, WI, AA Thr. at 6:00 p.m. Contact Mike L (920) 898-4782.

**MILWAUKEE COUNTY HOUSE OF CORRECTION**, 8885 S. 68th St. Franklin WI. **AA Women's** Saturday 10:00 a.m. Contact: Chris S. (414) 329-9310 or **AA Men's** on Sunday at 7:00 p.m. Contact: Dennis D. (414-372-8324

**MILWAUKEE COUNTY JAIL** 9th & State Milwaukee WI. Clearance needed at both facilities. **AA Women's** Sat. at 5:00 p.m. Contact Felisa C. (414) 672-6724. **AA Men's** Thr. at 7:00 p.m. Contact: John A. at (414) 915-9512

**MILWAUKEE SECURE DETENTION CENTER**, 1015 N. 10th St. Milw. Sunday Nights from 6:30 p. to 7:30 p., Men & Women, Call Marty S. at 414-975-8903 for information

**WAUPUN CORRECTIONAL INSTITUTION**  
AA Meeting Sat. , 8:00a.m.-9:30 a.m. Contact Dale C. 920-387-4229 after 5 p. clearance.

**FOX LAKE CORRECTIONAL**, Box #147, Fox Lake, WI 53933 Closed meetings Tue. & Fri. from 6:00 -8:00 p.m.

**JEFFERSON COUNTY JAIL** 411 S. Center St., Jefferson, WI, Mng. held on Mon. at 7:00 p.m., Contact: Scott N. 920-397-0170

**RACINE CORRECTIONAL INSTITUTION for MEN** Mtngs: Sun. 8:30 AM, Dane Rx Unit Wed. 7:00 p. Contact: Bill H. (262) 633-1851

**MILWAUKEE COUNTY CORRECTIONS COMMITTEE:** Meets 3rd Wednesday of each month at Faith United Methodist Church, 400 S. 91st St (91st & Adler). All Milwaukee County Corrections donations should be sent to: **MCCC, PO Box 270544, Milwaukee WI 53227-0544**. Call coordinator: Lynn G at 414-688-7164 with questions. Treasurer Bill E. at 414-433-3507. Corrections volunteers must go through the committee to get AA literature to take into the various facilities. Milwaukee Central Office no longer handles the funds.

## Area 75, Southern Wisconsin, Calendar of Events 2011

- Madison Senior Center (MSC), 330 W. Mifflin St. Madison, WI, except where otherwise noted.
- Feb 11-13 Delegates Past/Present in Appleton WI
  - Mar 27, Delegate Workshop
  - Apr 10, Pre-Conference Assembly
  - May 1-7, General Service Conference NYC
  - May 20-22, Spring Conf., Sheraton Brookfield
  - Jun 26, Summer Service Assembly
  - Oct 16, Fall Service Assembly
  - Nov 11-13, East Central Regional, Miamisburg OH

- Milwaukee Central Office:** 7429 W Greenfield Ave, West Allis, WI 53214 [gmco@aamilwaukee.com](mailto:gmco@aamilwaukee.com)
- Area 75 Treasurer:** PMB #167, 5464 N Port Washington Rd., Glendale WI 53217
- General Service Office:** G.S.O, P O Box 459, Grand Central Station, New York, N.Y. 10163
- Area 75 Corrections, Bridging the Gap and Treatment write to:** PMB # 170, 5464 N Port Washington Rd., Glendale WI 53217

("Mail" Continued from page 1)

I reflect for a moment and realize that I've but faintly scratched the surface in reaping rewards from membership in A.A. Sobriety, once my goal, is now secondary. Take friendship. Whereas I once sought to find it at bars, and many times accepted a poor substitute as genuine, I now have a sincere and lasting friendship with every member in my Group. I didn't realize that such sincerity existed in this world. I've heard many state that they couldn't say exactly what kept them dry. One of the chief reasons I stay dry is because I know that I'd have to forfeit the companionship of many fine friends if I returned to my former way of life.

From time to time I'm amazed at the change that has taken place in my personality. A short time ago I was critical, "cocky," resentful. Now I prefer to reserve opinion until I've examined a statement or situation objectively. I ask questions and seek advice of people at whom I once scoffed. I don't resent criticism, helpful or otherwise. And, thank God, I'm humble.

One thing I like about my new life is the insatiable interest I have in other people and their problems and needs. I'm interested in contributing what I can to their happiness, not for any material return. I like people now and want to help them.

Not so long ago I had a system of mental catharsis that was little different from that used by many people. A few Manhattans acted as a primer, generous gulps of rye or scotch put me in high gear. Then I

was ready to bend the ear of anyone happening to be near. I had a multitude of troubles and could consume hours telling about them, and I craved sympathy. My troubles have disappeared into thin air. And sympathy--I want none of it. I now consciously and objectively go through some form of mental catharsis each day. Used correctly I believe this is an all-round 365 day tonic. In conjunction with this I've set up a goal and budget for living, giving me no time for frequenting cocktail lounges if the urge should ever present itself.

Spiritually I've had a rebirth. Nothing miraculous has come about, nothing sensational that is, in the ordinary sense. But this transformation and rebirth of mine has something of the miraculous about it nevertheless. I read the Bible now, and though I haven't as yet gone back to church, intend to do so. I pray differently, too. I used to tell God I'd be good and do certain things if he'd do certain things for me. Now I ask God to help me so that I may help others.

When I was first admitted to A.A. I wondered about the sacrifices I'd have to make. I haven't made any sacrifices. The gain has been entirely on my side of the ledger.

I'm hanging on to A.A. and the happiness it's brought me. I'm hanging on with both hands and clutching it jealously, eagerly. I know it won't fail me. My miraculous rebirth attests to that. And speaking of miracles, I hope to help perform one tonight.

F.W.  
Scranton, Pennsylvania

Reprinted w/permission AA Grapevine, Inc.

("Possible" Continued from page 1)

conclusive, partial and not complete, tentative and not definitive.

It is impossible to dissect the human personality. Imponderables cannot be weighed and any analysis of individuality has its obvious limitations. The methodology of the scientist or the technique of the accountant are alike inappropriate in the examination of a man's soul or the evaluation of his character. Nonetheless, we recognize that in the alcoholic we are to a degree dealing with a specific type--a particular brand of neurotic--marked with definite peculiarities. However much we may generalize and say that these qualities are characteristic of all neurotics, and, indeed, are universal, we may find our understanding enlightened and our usefulness enhanced if we limit our investigation to the alcoholic as such.

The alcoholic eludes precise description. But some sort of working definition is helpful to an orderly, if unscientific, discussion. Provisionally, then, let us say that the person we are dealing with is an egocentric, defiant, narcissistic, self-sufficient individuality, supreme in his own domain, brooking interference by neither God nor man--or, more simply, a neurotic with an obsessional tendency--suffering a malady which is malignant, progressive and mortal.

Thus to state a proposition goes far to supply an answer to the problem inherent therein, and we can begin to see the reason for the lack of success of medicine and psychiatry in this field, preoccupied as they have been with superficial manifestations rather than basic causes. So those medical men, most experienced and knowledgeable, say, as Dr. Jung has said, that a vital spiri-

tual experience is essential to effect a recovery; or, as Dr. Tiebout has observed, that a spiritual force is used to attack the fundamental narcissism of the alcoholic; or, as Dr. Silkworth has stated, that an effort must be made to resolve the moral issue.

What the alcoholic, then, must remember, to paraphrase a statement from Le Comte Du Nouy's *Human Destiny*, is that the struggle against alcoholism has been transposed from the material onto the spiritual plane and that his own dignity, his nobility as a human being, must emerge from his efforts to liberate himself from his bondage and to obey his deepest aspirations. The distinguished biologist adds:

"And let [the alcoholic] above all never forget that the divine spark is in him, in him alone, and that he is free to disregard it, to kill it, or to come closer to God by showing his eagerness to work with Him, and for Him."

"To come closer to God" is another way of describing his "spiritual experience" which is "more than purely a psychological phenomenon arising only from his own resources" (say the authors of *Alcoholics Anonymous*). It is to have a "recurrence of birth" (what the Greeks call "palingenesis"), more simply and most significantly represented by the words of Jesus to Nicodemus when he said, "Except a man be born again, he cannot see the Kingdom of God."

But it is difficult to contact a person unless one has an affinity or something in common with him. Our conception of the duality of man's nature, human and divine, has obstructed as often as promoted our union with the Higher Power--usually because the idea has be-

("Possible" Continued on page 8)

("Possible" Continued from page 7)

come enmeshed in the technical vocabulary of theology and metaphysics. At this point, assistance to our understanding comes from a rather unexpected source, the now familiar monumental *A Study of History*, by that most scientific of world historians, A. J. Toynbee, who says:

"We may find an alternative starting point in the postulate that the divine nature, in so far as it is accessible to us, must have something in common with our own; and, if we look for one particular spiritual faculty which we are conscious of possessing and which we can attribute with absolute confidence to God. . . then the faculty which we shall think of first as being common to man and God will be one which the philosophers wish to mortify; and that is the faculty of Love. This stone which both Zeno and Gautama have so obstinately rejected is become the head of the corner of the temple of the New Testament."

**II.** What does the beginner bring to A.A. in the way of liabilities which handicap and assets which aid his attempt to achieve that regeneration which will both rid him of his alcoholism and start him on the road to his proper destiny?

On the debit side there is, among other things, the matter of will power, the lack of which is frequently said to be the root of the alcoholic's trouble. And it is undeniably true, that the active alcoholic when in the grip of the alcoholic obsession, seems powerless to reject a drink. But as has been suggested in an earlier discussion (*A.A. Grapevine*, April, 1947), there is the power of volition which has never been lost, namely, the ability to make the initial decision represented by the 1st Step of the Pro-

gram; witness the thousands of "condemned" alcoholics who have made the choice. Moreover, our whole philosophy is predicated on the proposition that man is a free moral agent, otherwise there could be no moral responsibility.

Yet, in respect of daily action as well as ultimate goals, the will appears to be atrophied to a large extent. It cannot be reactivated, however, on the false theory that the will is a separated or insulated organ that can be treated by a "muscular" therapy. The will is a composite faculty, a union of the soul's energies, requiring for its fullest exercise the proper motivation, guidance and direction. Self-examination which reveals debris to be cleaned out, the adoption of new attitudes towards old values and the establishment of new aims and objectives will bring about the complete liberation of the will and the release from alcoholic bondage which permit a person to attain his highest destiny. The catalogue of things to be done sounds formidable but the comforting feature of the matter is that they can be done a little at a time. And the saving grace of the situation is that this is exactly what the 12 Steps are designed to accomplish.

Another liability encumbering the candidate is a general lack of faith. Faith in one's fellows is quickly restored by contact with A.A. members. Faith in a Higher Power is often not so quickly revived. It is a great handicap for an alcoholic to lose, as many do, his spiritual anchorage. Having no aims, life being bereft of purpose and significance, the alcoholic feels no compelling reason to stop drinking. Having rejected divine aid, human assistance being insufficient, he feels it hopeless even to attempt a recovery.

("Possible" Continued on page 9)

("Possible" Continued from page 8)

This, undoubtedly, is the greatest handicap of all, but we know that the suggestion, during the course of the Program, of a Power greater than himself insidiously, almost surreptitiously, frees the man from frustration, fear, anxiety and resentment; brings about self-realization and discipline; and eventually there comes a free recognition of God and lavish self-helping of His bounty.

Turning to the asset side, there are at least three redemptive qualities which the Program turns to good account. The instinct of gregariousness is an outstanding attribute of most alcoholics. Actuated by this basic desire, the habit of seeking the association or company of others is formed and practised to an extent enlarged by the liquidation of any introversion that may be inherent in the subject. The frequent and more or less systematic foregathering of the clan for the purpose of drinking, conversation, self-improvement and mutual admiration and criticism, is a

phenomenon too common to require comment. Equally obvious is the same phenomenon observed in A.A. circles, as are also its therapeutic value when it occurs at the A.A. level.

Another property of the alcoholic (by no means restricted to him) is an inherent altruism. In the conflict between egoism and altruism, the impulse to help others often prevails. It is characteristic of the alcoholic and is reflected even during his drinking period. Herbert Spencer long ago observed that every generation of social living deepens the impulses to mutual aid. The altruization of the behavior of persons and groups is currently the subject of analysis and investigation with a view to bringing about harmony among groups, societies and nations. It has been said that each man can quicken the pace of moral evolution (*du NoÃ¼y supra*). None is more qualified to do so than the alcoholic by virtue of his possession of the quality of altruism.

("Possible" Continued on page 16)

# CLUB INFORMATION

## NEW DAY CLUB

11936 N. Port Washington  
Mequon, (262) 241-4673  
<http://www.newdayclub.org>

### A.A. MEETING SCHEDULE

Sun. 8:00 a.  
11:00 a.  
5:00 p. Young People  
7:30 p. Sun. Night Topic

Mon. 12:30 p. Tenth Step Gp  
5:30 p.  
7:00 p.  
8:15 p. Men's Gp

Tue. 10:00 a.  
5:30 p. Topic Meeting  
7:00 p. Beginners Gp  
8:00 p. Big Book Gp

Wed. 10:00 a.  
2:00 p. Promises Meeting  
5:30 p. Step Meeting  
7:30 p. Women's Gp

Thr. 10:00 a. Topic Meeting  
1:00 p. Women's Gp  
5:30 p. Topic Mtng.  
8:00 p. Step Meeting

Fri. 10:00 a. Topic Meeting  
5:30 p. Step/Tradition  
8:00 p.

Sat. 10:00 a. Step Meeting  
5:00 p. Steps/Principles  
7:00 p. (Feelings)  
10:00 p. Young People

8:00 p. Open Meeting (held on 3rd Saturday of month only)

AL-ANON MEETINGS  
Monday 6:30 p. Al-Anon  
Tuesday 1:00 p. Al-Anon/ACOA  
Thursday 7:00 p. Al-Anon  
Contact club for info on other fellowships.

## PASS IT ON CLUB

6229 W. Forest Home Ave Milw, WI  
(414) 541-6923 [passitonclub.com](http://passitonclub.com)

### A.A. MEETING SCHEDULE

Sun. 8:00 a. Sun. Wake Up  
9:30 a. Reliance Open Disc.  
11:00 a. Today choice  
3:00 p. Gratitude Plus  
7:00 p. Big Book Readers  
7:30 a. Jump Start  
10:30 a. First Step  
4:00 p. Happy Hour Step

Mon. 7:00 p. Mon. Freedom  
7:00 p. Open IntroductoryAA

Tue. 7:30 a. Comin' Back Gp  
10:30 a. Keep It Simple  
4:00 p. Drop the Rock  
6:00 p. Women's Step  
7:30 p. Three Legacies  
7:30 p. Double Trouble DD/O

Wed. 7:30 a. Big Book Study  
10:30 a. Pass It On  
4:00 p. Happy Hr Promises  
7:00 p. We, Us & Ours

Thr. 7:30 a. Welcome Back Gp  
10:30 a. Made Decision  
5:15 p. As Bill Sees It  
7:00 p. Gateway Topic Gp  
7:30 a. Honesty Gp

Fri. 10:30 a. Came To Believe  
6:00 p. Women's Fri. Kickoff  
6:30 p. Thoughts 4 Today  
8:00 p. Spanish Speaking  
8:00 p. Group # 1

Sat. 8:30 a. Early Bird  
10:30 a. Happy Joyous Free  
3:00 p. Twelve Promises  
8:00 p. Back to Basics

12x12

### AL-ANON MEETINGS

Sun. 11:00 a. Thr. 7:00 p.  
Tue. open (Alateen)  
Wed. 7:00 p. Fri. 7:30 p.  
Sat. 10:30 a.

## LAKE AREA CLUB

N60 W 35878 Lake Dr  
Oconomowoc, WI  
(262) 567-9912

Visit our website at:  
[www.lakeareclub.com](http://www.lakeareclub.com)

### A.A. MEETING SCHEDULE

Sun. 8:00 a.  
11:00 a.  
6:00 p. Big Book  
8:00 p.

Mon. 9:00 a. Positive Attitude  
6:30 p.  
8:00 p. Step/Tradition Stdy

Tue. 1:00 p.  
8:00 p. Back To Basics

Wed. 8:00 a.  
10:00 a.  
6:00 p.  
8:00 p.

Thr. 10:00 a.  
6:00 p. Women's Group  
8:00 p.

Fri. 12:30 p.  
6:00 p. Non-smoking  
8:00 p.

Sat. 8:30 a.  
10:00 a. Big Book  
8:00 p.

### AL-ANON MEETINGS

Mon. 8:00 p. Al-Anon  
Tue. 9:00 a. Al-Anon  
Wed. 7:00 p. Al-Anon

### OPEN SPEAKER MEETING

Sat. 7:00 p. 2<sup>nd</sup> & 4<sup>th</sup> Saturdays  
(AA and/or Al-Anon Speakers)

## UNITY CLUB

1715 Creek Drive  
West Bend, (262) 338-3500  
<http://www.unityofwb.com>

### AA MEETING SCHEDULE

Sun. 10:30 a.\*\* Gratitude Gp.  
8:00 p.\* Candlelight Gp.

Mon. 10:00 a. Monday A.M.  
7:00 p. Men's

Tue. 10:00 a. Tuesday A.M.  
7:30 p. Beginner's  
8:00 p. Step Gp

Wed. 10:00 a. Promises  
8:15 p. Step Gp

Thr. 10:00 a. Big Book  
8:00 p. Young People

Fri. 10:00 a. Step/Topic Gp  
8:00 p.\*\*\* Step Gp.

Sat. 10:00 a. Here & Now

### AL-ANON & ALATEEN MTNGS

Monday 6:30 p. Alateen  
Wednesday 8:15 p. Al-Anon

\* Open Mtng. 1st Sunday Quarterly  
\*\* Open Mtng. 3rd Sunday of month (a.m.)  
\*\*\* Open Mtng. last Friday of month

## WAUKESHA ALANO CLUB

318 W. Broadway  
Waukesha, WI  
(262) 549-6541

### A.A. MEETING SCHEDULE

Sun. 11:00 a. Sun Go-To-Mtng  
(Open speaker 2nd Sunday & Breakfast)  
7:00 p. (Open Step Gp)

Mon. 12:00 Noon  
6:00 p. Beginners AA  
7:00 p. (12 & 12)

Tue. 12:00 Noon

Wed. 12:00 Noon  
5:30 p. Topic Gp  
8:00 p.

Thr. 12:00 Noon  
8:00 p.

Fri. 12:00 Noon T.G.I.F. Gp

Sat. 10:00 a. Gp 124  
7:00 p. Closed Meeting

**OPEN MEETINGS,  
DANCES & EVENTS  
Call for information.**

## SERENITY CLUB

3677 E. Pulaski Ave,  
Cudahy, WI 53110,  
(414)483-8308  
[serenityclub.info](http://serenityclub.info)

### AA Meetings

Sun. 10:00 a. Welcome Gp.  
7:00 p. Gp. 83

Mon. 10:00 a. Honesty Gp.  
6:30 p. Ladies Big Book  
8:00 p. Sharing Strength

Tue. 10:00 a. Gp. 118  
8:00 p. Gratitude Gp.

Wed. 10:00 a. Rap Discussion  
5:30 P. Courage/Change  
8:00 p. 1 Day At A Time

Thr. 10:00 a. Gp. 89  
8:00 p. Gp. 88

Fri. 10:00 a. Gp. 41  
6:30 p. Broken Arrow  
8:00 p. Gp. 449

Sat. 10:00 a. Reliance Gp.  
7:00 p. Big Book Gp.

AL-ANON MTNG: Sunday 5:30 p.  
AL-ANON MTNG: Tuesday 6:30 p.  
ALATEEN MTNG: Tuesday 6:30 p.  
AL-ANON MTNG: Friday 7:30 p.

Call Club for Open Meeting  
& Dance Information

## MEETING at CENTRAL OFFICE

Saturdays at 10:30 A.M.

"WRITTEN FOR US"

### 12 + 12 Step Book

Alternating with **Big Book**  
reading every other week.  
(Bring your Big Books and 12 & 12's)

One Room, One Group Discussion,

ONE HOUR!

Milwaukee Central Office

7429 West Greenfield Avenue

West Allis WI 53214, 414-771-9119

# CLUB INFORMATION

## WALWORTH COUNTY ALANO CLUB

611 Walworth St.  
(Hwy. 50 & 11)  
Delavan, WI 53115,  
(262) 740-1888

### Sunday AA

10:00 a. Primitive Group  
12:00 Noon Open Speakers  
6:30 p. Delavan Discussion

### Monday AA

7:30 a. Delavan Sunny Side Up  
12:00 Noon Delavan Step Meeting  
6:30 p. Former Miss Americas  
(Women's Step Group)  
6:30 p. Delavan Men's Meeting

### Tuesday AA

7:30 a. Delavan Sunrise Tue  
12:00 Noon Delavan Noon Gp.  
6:30 p. Delavan 12 Step Topic

### Wednesday AA

7:30 a. Delavan Sunrise Wed.  
12:00 Noon As Bill Sees It Gp.  
6:30 p. Delavan IT Meeting

### Thursday AA

7:30 a. Delavan Sunrise Thr.  
12:00 Noon Delavan Noon Gp.  
5:30 p. Step Sisters Women  
6:30 p. Delavan Big Book Gp.

### Friday AA

7:30 a. Delavan Sunrise Fri.  
12:00 Noon Big Book Study  
6:30 p. Delavan Discussion  
8:00 p. Delavan Candle-less Gp.

### Saturday AA

12:00 Noon Delavan Noon Gp.  
6:30 p. Delavan Beginners Gp.

ALANO CLUB 1521 N. Prospect Ave.  
Milwaukee, WI (414) 278-9102  
<http://www.alanofoundation.com>

### A.A. MEETING SCHEDULE

Sun. 10:00 a. Gp 17 Step  
4:30 p. Step Gp  
7:30 p. Gp 19 Step  
10:00 p. Topic Gp  
Mon. 7:00 a. Early Morning  
10:30 a. Gp 72 Topic  
12:15 p. Big Book Meeting  
5:30 p. Gp 12 Monday Blues  
6:30 p. Gp 40 Big Book  
8:00 p. Gp 20 Topic  
10:30 p. Living Sober Step/Topic  
Tue. 7:00 a. As Bill Sees It.  
10:30 a. Gp 70 Step  
12:15 p. Gp 76  
5:30 p. Men's AA & Al-Anon  
8:00 p. Beginners - 1st Step (3rd fl)  
8:00 p. Gp 57 Topic  
10:30 p. 4th Dimension Step/Topic  
Wed. 7:00 a. Men's Step  
10:30 a. Gp 9 Step  
12:10 p. Oasis Topic Gp  
6:00 p. Gp 91 Women's  
8:00 p. Gp 3 Step/Topic  
10:30 p. Step/Topic Gp  
Thr. 7:00 a. Big Book Meeting  
10:30 a. Gp 97 Step  
12:15 p. Here & Now Gp  
5:30 p. Acceptance Topic  
7:00 p. LGBT Big Book  
7:30 p. Gp 26 12x12  
10:30 p. As Bill Sees It  
Fri. 7:00 a. Daily Reflections  
10:30 a. Gp 21 Step  
12:15 p. Gp 65  
6:30 p. Here & Now  
8:30 p. Gp 30 Tub Topic  
11:30 p. Step/Topic  
12:15 a. Second Shifters  
Sat. 11:00 a. Gp 87 Step  
3:00 p. Spiritual Growth  
7:30 p. Open Speaker  
9:00 p. Here and Now  
11:30 p. Tub-Topic

AL-ANON MEETING Sunday 10:00 a.  
Club is smoke free. Many meetings break  
outdoors for smoking.

## H.O.W. TO CLUB

8930 W. National Ave,  
West Allis, (414) 543-2448

<http://howtoclub.info/>

Sun. 8 a.-11 p.  
Mon - Thr. 9 a. - 11 p  
Fri - Sat. 9 a. - 1 a.

### AA MEETING SCHEDULE

Sun. 8:00 a. Eye Opener AA Gp.  
10:00 a. Grass Roots (Steps)  
4:30 p. Drop the Rock 6/7 Step  
6:00 p. AA Topic Group  
8:00 p. Sun. Sober & Serene  
Mon. 11:00 a. Winner's Circle  
5:45 p. Gp 132, Women's Gp  
7:00 p. Big Book Gp.  
8:00 p. New Hope Gp.  
11:15 p. Nighthawk Gp.  
Tue. 11:00 a. Willingness Group  
6:00 p. Tuesday Non-Smok  
8:00 p. 12 & 12 AA Meeting  
Wed. 10:00 a. Foundations Meeting  
6:00 p. AA Beginners Gp.  
7:00 p. Women's Freedom  
8:00 p. Promises Group  
11:15 p. After Hours Gp.  
Thr. 10:00 a. But For Grace Of God  
6:00 p. 6 PM Here and Now  
8:00 p. How To Get It Going  
Fri. 11:00 a. Priority Group  
6:00 p. Big Book Group  
8:00 p. R.U.S. For Us  
11:15 p. Candlelight Promises  
Sat. 9:15 a. Men's Topic  
11:00 a. Pioneers Group  
6:00 p. 1st & 12 Topic  
8:00 p. HOW To Saturday\*)  
\*(Open meeting on 3rd Saturday)  
10:30 p. Candlelight Gratitude

# CLUB INFORMATION

## FRIENDSHIP CLUB

2245 W. Fond du Lac  
Ave. Milwaukee, WI  
414. 931.7033

### AA MEETING SCHEDULE

#### Sunday:

10:00 a. Friendship Gp  
11:00 a. Third Sunday  
Open Meeting

#### Monday:

10:30 a. Step Gp

#### Saturday:

10:00 a. Gp 112

Call for information on  
other types of  
meetings.

## 12 STEP CLUB

4102 W Townsend St.  
Milwaukee, WI 53216  
(414) 871-0610

### A.A. MEETING SCHEDULE

Sun. 10:00 a. Gp. 24 Upstairs

Mon. 11:00 a. Gp. 92

Tuesday **No AA Meeting**

Wed. 11:00 a. Gp. 27

Thursday 07:00 p. Here & Now

Fri. 11:00 a. Gp. 61 (12x12)  
6:00 p. Women's Gp.

Sat. 10:00 a. Beginners Gp.  
7:00 p. Gp 6

CALL THE CLUB FOR  
INFORMATION ON OPEN  
A.A. MEETINGS,  
MEETINGS FOR OTHER FEL-  
LOWSHIPS and  
SPECIAL EVENTS.

## 1907 CLUB

2908 N 21st St.  
Sheboygan, WI 53083  
(920) 457-9633

### AA MEETING SCHEDULE

Sun: 7:00 p. As Bill Sees It  
Mon: 6:30 p. Old Timers  
7:30 p. Women's  
8:00 p. Beginners  
Tue: 6:00 p. Big Book  
Wed: 9:30 a.

8:00 p. WITTS  
Thr: 6:00 p. Topic Meeting  
7:00 p. Closed Speaker  
Fri: 8:00 p. Good Fight Gp  
Sat: 9:30 a. Non-Smoking  
6:30 p. Grapevine

Mtng  
**Open Meeting 1st & 3rd**  
Saturday of month at 8:00 p.

### Al-Anon Meetings

Monday: 7:00 p. Al-Anon  
Wednesday: 9:30 a. Al-Anon  
Saturday: 9:30 a. Ala-teen  
9:30 a. Ala-Tot  
9:30 a. Al-Anon

The "Clubs" listed here are not A.A. Clubs. **A.A. DOES NOT HAVE CLUBS!**

A.A. neither endorses nor opposes such clubs. These are social clubs established by groups or individuals who are themselves recovering alcoholics. The A.A. group meeting at the club is available to any alcoholic - club member or not. The group is separate from the club and pays a fair rent for the use of the club facilities. Even though the group meets in a club that may be composed exclusively of A.A. members, and many members of the group may be club members, too, the relationship of the A.A. group itself to the club should be the same as it would be to a church, hospital, school, etc., in which it might rent space for its meetings.

# When and Where

## NEW MEETINGS

**The First 164**, Roundy's Memorial Baptist, 4819 N Ardmore at Hampton, Whitefish Bay. Meets on Tuesday's at 5:45 p.

**Polish Sober Eagles (Polish Speaking)** Prince of Peace, 4419 S Howell Ave Milwaukee 53207 (rear parking, rear entrance) Meets on Tuesday and Friday at 6:00 p. (Russian Interpreter available)

**Bright Spot of Our Lives Young People**, St James Congregation W222 N6570 Town Line Rd, Meno-

nee Falls Wednesdays at 7:00 p.

**UW-Whitewater**, Ambrose Health Center, 800 W Main St, Whitewater, Wednesdays at 4:00 p.

**By The Book**, Tippecanoe Presbyterian, 125 W Saveland Ave Milwaukee 53207 Wednesday, 7:00 p.

**LGBT Friendly**, Milwaukee Metropolitan Community Church, 1239 W Mineral St. Milwaukee 53204. Thursdays at 6:30 p.

Thursdays at 6:30 p.

## DISBANDED GROUPS

**Group 94 (Gay)** All Saints Cathe-

## 24 HOUR CLUB

153 Green Bay Rd.  
Thiensville, WI  
(262) 242-9999

### A.A. MEETING SCHEDULE

Sun. 8:00 a. Topic  
10:00 a. Step/Topic  
5:00 p. Step  
Mon. 6:30 a. Topic  
10:00 a. Topic  
12:00 p. Women's  
8:00 p. Men's  
Tue. 6:30 a. Topic  
10:00 a. Step/Topic  
5:30 p. Big Book  
Wed. 6:30 a. Topic  
10:00 a. Big Book  
5:15 p. Women's  
Thr. 6:30 a. Topic  
10:00 a. Topic  
5:30 p. Step/Topic/Trad  
Fri. 6:30 a. Topic  
10:00 a. Step/12 & 12  
5:30 p. Principles  
8:00 p. Step  
Sat. 8:30 a. Living Sober  
10:00 a. Big Book

8:00 p. Open Speaker Mtng.  
(1st Saturday Only)

## GALANO CLUB

### - LGBT Recovery -

315 W. Court St. Suite 201  
Milwaukee, WI 53212-3825  
(414) 276-6936

<http://www.galanoclub.org/>

[mail@galanoclub.org](mailto:mail@galanoclub.org)

### MEETING SCHEDULE

Sun. 10:30 a. Step Topic  
Mon. 7:30 p. Came To Believe  
Tue. 5:30 p. 40+ Topic  
Wed. 7:00 p. 12 x 12  
Fri. 7:00 p. Step/Topic  
Sat. 7:30 p. Topic

### AL-ANON MEETINGS

Sun. 10:30 a.m. (Co-ed.)

CALL THE CLUB FOR INFO ON  
SPECIAL EVENTS AND OPEN  
MEETINGS!

## NORTHWEST ALANO CLUB\*

N88 W17658 Christman Rd  
Menomonee Falls WI  
53051 (No Phone)

### A.A. MEETING SCHEDULE

Sun. 7:30 p.  
Mon. 7:00 p.  
8:00 p. Action Gp  
Tue. 10:00 a. Step  
8:00 p.  
Wed. 8:00 p. Step/Topic  
Thr. 10:00 a. Step  
6:00 p. Women's  
Fri. 8:00 p. Step/Topic  
Sat. 10:00 a. Step

### AL-ANON MEETINGS

Wed. 8:00 p. Al-Anon  
Fri. 8:00 p. Al-Anon

\*This Club is a Smoke-Free environment. We have ample meeting space available for 12 Step groups. Contact the Northwest Alano Club by mail.

dral, 818 E Juneau, Milwaukee, met on Sundays at 6:00 p.

**Brown Deer Friday**, Abiding Savior, 5214 W Luebbe Ln, met on Fridays at 8:00 p.

**Cudahy Into Action**, Cudahy United Methodist, 5865 S Lake Dr. Cudahy, met Saturdays at 7:00 p.

### OTHER CHANGES

**Women's Step & Promises**, formerly met at Holy Trinity, 11709 W Cleveland, **NOW** meets at Grace Bible Church **2643 S 117 St** West Allis, Monday at 6:00 p.

**Gp No 2, 10 am Tuesday**, formerly at Sacred Heart 3641 S KK Ave, **now** meets at Bay View United Methodist 2772 S. Kinnickinnic Ave, Milwaukee

**Friday Night Second Shifter's** formerly met at Serenity Club, now meets at the Alano Club, 1521 N Prospect Ave Friday night/Saturday morning at 12:15am

**Fri North Shore**, Bay Shore Lutheran, 1200 E Hampton, formerly at 8 p. now meets at 7:30 p.

**St Anskar, N48 W31340 Hill Rd** Hartland: Thursdays meets at 7:00 p. and Fridays now meets at 8:00 p.

## OPEN MEETINGS

**Weekly & monthly open meetings listed in December 2010, When & Where**

[aamilwaukee.com/directory.html](http://aamilwaukee.com/directory.html)

Grapevine Open Meeting, Pass It On Club, 6229 W. Forest Home Ave. meets on **Sundays at 5:00 p.**

**AA OPEN MEETING at the VA**, 5000 W National Ave, Milwaukee, Dom 43 Cafeteria, **Monday November 8, 7pm**

West Allis Memorial Hospital, (Conf. Rm. B), 8901 W. Lincoln Ave., **Sundays at 4:30 p.** Ace Boxing 1st Monday Open Meeting, 2160 S. 10 St., Milw., meets **1st Monday at 7:00 p.**

Bethesda Seniors Community Center Open Meeting, 2845 W Fond du Lac Ave **1st Monday at 1:30 p.**

Salem United Methodist Church, 541 Hwy. 59, Waukesha, ea. **Wed. 7:00 p.**

St. Lukes Church, 300 Carroll St., Waukesha **1st Friday only 8:00 p.**

24 Hour Club Open Meeting, 153 Green Bay Rd, Thiensville, **First Saturday of month at 8:00 p.**

New Hope United Church, 4360 N. Jackson Dr., Jackson WI, meets on **Second Saturday only at 7:00 p.m.**

Dist 34, St. Francis Episcopal Church, N84 W16525 Menomonee Ave., **Second Saturday at 7:00p.**

Waukesha Alano Open Mtng. 318 W. Broadway, Waukesha, **2nd Sunday, at 11:00 a.**

Open Meeting 2245 W. Fond du Lac Ave. Milwaukee, WI. Meets on **3rd Sunday at 11:00 a.**

HOW To Club Open Meeting, 8930 W. National Ave., **3rd Saturday 8:00 p.**

New Day Club Open Meeting, 11936 N. Port Washington Rd, Mequon, **Third Saturday at 8:00 pm**

Trinity United Church of Christ, 4435 N. Calhoun Rd. **Last Wed. 8:00 p.**

Holy Assumption School, 72<sup>nd</sup> & Orchard, **Last Wednesday 8:00 p.**

Holy Hill Friday Night Open Meeting, Parish House, 1525 Carmel Rd. Hubertus, **3rd Friday of May and September at 7:30 p.**

New Day Club Open Meeting, 11936 N. Port Washington Rd., Mequon, **Third Saturday at 8:00 p.**

Alano Club Open Meeting, 1521 N. Prospect Ave **Every Saturday 7:30 p.**

Contact the Central Office, E-mail: [gmco@aamilwaukee.com](mailto:gmco@aamilwaukee.com), before the 12th of the month prior to your Open Meeting so that it can be listed here under the special/ anniversary Open Meetings section.

# 5/5

## "Faithful Fivers"

**Greater Milwaukee Central Office**  
**7429 W. Greenfield Ave. West Allis WI 53214**

**Faithful Fivers** "When we meet and defeat the temptation to take large gifts, we are only being prudent. But when we are generous with the hat, we give a token that we are grateful for our blessings and evidence that we are eager to share what we have found with those who still suffer." - *Bill W.*

Every single AA service is designed to make 12th Step work possible. As a **Faithful Fiver** your personal contributions can and will make our vital services possible. You can start with a minimum monthly contribution of \$5.00 or more. This can be paid by check or billed to your credit card.

**Yes! I want to participate in the Faithful Fivers Club.**

**Contribution Information: Date:** \_\_\_\_\_  
**Amount \$:** \_\_\_\_\_ **Monthly** \_\_\_\_\_ **Quarterly** \_\_\_\_\_ **Annually** \_\_\_\_\_

(Note no AA member can contribute more that \$3000 per year)

I am a new member \_\_\_\_\_ a current member \_\_\_\_\_ a returning member \_\_\_\_\_.

Payment Plan:

Check enclosed: \_\_\_\_\_ or Bill my credit card: Visa \_\_\_\_\_ M/C \_\_\_\_\_ Discover \_\_\_\_\_

**Card #:** \_\_\_\_\_ - \_\_\_\_\_ - \_\_\_\_\_ - \_\_\_\_\_

**Expiration Date:** \_\_\_\_/\_\_\_\_/\_\_\_\_

**Name** \_\_\_\_\_

**Address** \_\_\_\_\_

**City** \_\_\_\_\_ **State** \_\_\_\_\_ **Zip** \_\_\_\_\_

**Phone Number** (\_\_\_\_) \_\_\_\_\_ - \_\_\_\_\_

### 2011 Weekend Retreats Jesuit Retreat House, Oshkosh, WI [jesuitretreathouse.org](http://jesuitretreathouse.org)

Men and Women members of AA, Al-Anon  
Total cost: 4 days \$290.00. Send a \$40.00 deposit with requests for specific dates to: Jesuit Retreat House, 4800 Fahrwald Road, Oshkosh, WI 54901 or call for information, 1(800) 962-7330  
May 5-8 Men, Fr Peter O'Brien, S.J.  
May 12-15 Women, Fr: Tom Weston, S.J.  
May 19-22 Men, Fr Tom Weston, S.J.  
Aug 18-21 Women, Mildred Frank  
Nov 10-13 Women, Sr Kerry Larkin OSM  
Nov 17-20 Women, Sr Elise Cholewinski OSF  
Dec 01-04 Men, Fr Kevin Ballard, S.J.

### Spanish Speaking Meetings: Meeting at English Speaking Clubs

- GRUPO 5 CONCEPTOS, Pass It On Club, 6229 W. Forest Home Av, Milw, on Friday at 8:00 p.
- GRUPO NUEVO AMANECER, Tri-County Unity Club, 104 N. First St, Watertown, on Tuesdays and Fridays at 7:00 PM and on Sunday at 11:00 AM
- GRUPO FE Y ESPRONZA, Gratitude Club, 295 Ruggles St. Fond du Lac WI on Wednesday at 7:00 PM and Sundays at 4:00 PM

### MILWAUKEE CENTRAL OFFICE

- **E-mail the Board President at:** [board@aamilwaukee.com](mailto:board@aamilwaukee.com)
- **E-mail Director Jim B. at:** [jim@aamilwaukee.com](mailto:jim@aamilwaukee.com)
- **Hours:** 9 a.m. to 6 p.m. Mon.-Fri.; 9 a.m. to 5 p.m. on Saturday
- **G.S.R. Orientation, 2<sup>nd</sup>** Tuesday 6:30 p.
- **Secretary Meeting, 2<sup>nd</sup>** Tuesday 7:00 p.
- **Board of Directors Meeting,** Wednesday following Secretaries Meeting, (odd numbered months) 7:00 p.
- **A. A. Meetings,** Mon - Fri at 12:15 p. and 4:00 p.
- **A. A. Meeting Saturday** 10:30 a. and 3:00 p.
- [www.aamilwaukee.com](http://www.aamilwaukee.com)

## Milwaukee Area Districts Holiday Alkathon Summary

The 2010 Milwaukee Area Holiday Alkathon was another success with the participation of 41 groups over 4 days. The committee would like to thank everyone who attended the meetings. We had a series of great meetings, fantastic fellowship and wonderful food. A special thanks to the clean-up volunteers, they did a job that was second to none.

Here are the money details:

7 <sup>th</sup> Tradition		Expenses	
Dec 24	\$ 195.66	Rent	\$ 200.00
Dec 25	\$ 285.34	Coffee	\$ 180.00
Dec 31	\$ 143.05	Supplies – drinks	\$ 164.84
Jan 01	\$ 284.50	Supplies – literature	\$ 84.94
<b>Total</b>	<b>\$ 908.55</b>	Supplies – Water	\$ 3.00
		<b>Total Costs</b>	<b>\$ (632.78)</b>

Beginning Checking Account Balance	\$ 875.67
7 <sup>th</sup> Tradition	\$ 908.55
<b>Total Funds</b>	<b>\$ 1,784.22</b>
Less Expenses	\$ (632.78)
<b>Prudent Reserve</b>	<b>\$ (650.00)</b>

### Distribution of 7<sup>th</sup> Tradition Fund Greater than Prudent Reserve

Area 75	\$ 291.78
Central Office	\$ 291.78
GSO	\$ 145.89

This leaves a prudent reserve of \$ 650, which is in accordance with the GSO recommendations of retaining one year's operating expenses.

Eddie P would like to express his gratitude to everyone that participated the last two years with the committee. He has turned the chair over to Mike T, who was elected by the committee, but remains as an advisor.

We hope that you have a safe and sober year.

Respectfully submitted in service,

The Alkathon Committee

(Gail S, Mike T, Charlie K, Bryan P, Manny M, Eddie P, Vickie W, Bruce G, Rick K)

("Possible" Continued from page 9)

If he can find, as he does in A.A., a constructive outlet for the altruistic urge, he obtains his own release and may become a factor of uncommon significance in the evolutive transformation of mankind from physiological slavery to spiritual freedom.

### Anything Is Possible

The last asset possessed by every alcoholic, no matter how depraved, to which reference will be made, is the element of divinity which is present in every man. Without this, little could be done; with it, nothing is impossible. A.A. in its empirical way has demonstrated that "there is that of God in every man." This and this alone makes no damage to the human personality irreparable. This and only this makes it possible to

say that no alcoholic is beyond redemption. Upon this proposition depends the ultimate validity of every technique and procedure employed in the Program. Our hopes and our realization thereof rest on the premise and the promise that man is not merely an automaton reacting to a physio-chemical determinism, but a person created in the image and likeness of God with whom he may become a communicant, whose power he may draw upon, by reason of his kinship, once the decision is made and some effort shown. This is the alcoholic's primary asset upon which no creditor can levy but which, under A.A. auspices, may be the subject of benign inflation.

R.F.S.  
Montclair, New Jersey

Reprinted w/permission of AA Grapevine, Inc

## DISTRICT 16 PRESENTS Our 2<sup>nd</sup> Annual OUR MARCH INTO SOBERITY

AN CEEN SPEAKER MEETING



**Where: Milwaukee Central Office**

**7423 West Greenfield Avenue West Allis, WI 53214**

**When: March 6<sup>th</sup> 2011**

**Hospitality starts at Noon**

**AA Speakers start at 1:00 pm**

**First Speaker: Paul E. (Milwaukee)**

**Second Speaker: Mike C. (Manitowoc)**

**Please come join us, there will be District 16 Chair people to answer questions and share information about how we can carry the message to all in our district and beyond**



**Coffee and snacks will be available**

**Please feel free to bring your favorite snack to share**



**Join us for the 33<sup>rd</sup> Annual Snow Ball**  
**Fundraiser to support the Al-Anon Service Center of SE Wisconsin**

**Dinner, Drawing, Speakers & Dance**

**Saturday, February 12, 2011**

Serb Hall 5101 W Oklahoma Ave

**Dinner 4:30-6:00 pm**

**Speakers 7:00 – 9:00 pm**

**Dance 9:30-12:00 midnight**

Speakers:

Al-Anon – Ramona C. – Chicago, IL

AA – Max M. – Chicago, IL

Alateen- TBA

Donations:

**Dinner & Dance Tickets: \$25**

**Dance Only Ticket: \$10**

Dinner Choices:

Sliced Beef or

Chicken Breast w/wild rice

Contact the service center office for tickets:

AFG of SE WI

6737 W. Washington

West Allis, WI

414-257-2415



**Big Ticket Drawing!\***

Make quick work of your cleaning projects with a new **Pressure Washer**, 2500 PSI Gas Powered, with Detergent Injection and 4 quick-connect spray tips

Then, when the work is done, head off for a couple of days of fun & sun!



**Family Fun Pack**

Including Gift Certificates for Country Springs Hotel & Water Park in Pewaukee (can be used anytime for any of the amenities), and

Join another family for a Day on Pewaukee Lake with all the toys! (Including boating, swimming and lunch), and More Items to come!

\* Need not be present to win. **Pressure Washer** and **Family Fun Pack** to be offered in separate drawings. Tickets available through the service center and at the event.

**GROUP # 48's**  
**39<sup>th</sup> Annual Open Meeting**  
**Saturday February 19, 2011**

Immaculate Conception

1051 E. Russell Avenue

Milwaukee, WI. 53207

**Al-Anon Speaker: Kay B.**  
**AA Speaker: Bob B.**  
 (Past Delegate Area 75)

**5:00PM To 6:00P.M. Hospitality**

**6:00PM to 7:00P.M. Dinner**

**7:00PM to 9:00 P.M. Speakers**

**Dinner tickets: \$10.00**

**Ticket sales deadline February 14<sup>th</sup>, 2011**

Call **John B. 414-727-0716**

**Ken N. 262-835-1296**

**RESERVE THE DATE FOR A  
 GREAT WORKSHOP**

**Bay View United Methodist Church**  
**2772 S Kinnickinnic Ave**  
**Milwaukee, WI 53207**

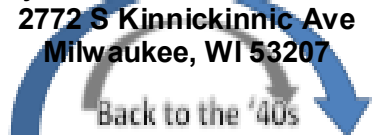

**Back to the '40s**

**March 19<sup>th</sup> & 20<sup>th</sup>, 2011**

Over two days, we cover the 12 steps of AA as discussed in the first 164 pages of the Big Book, Alcoholics Anonymous.

Mike & Ray, from St. Pete, FL, discuss the History of AA and walk us through the 12 Steps as was done back in the 40s by early groups of AA.

**COME JOIN DISTRICT 29**  
**BI-MONTHLY OPEN MEETING**  
**ROUND ROBIN**

Where: Episcopal United Church of Christ  
 1927 West Forest Home Ave - Hales Corners, WI

Time: 7:00 pm AA and Alanon Speakers Carry Their Message

Dates: The second Sunday of the following months  
 Mark your calendars for these dates

February 13	A Vision For You
April 10	Group 90
June 12	TBA
August 14	TBA
October 9	Saturday Morning Early Birds
December 11	TBA

**COME JOIN US FOR  
 FELLOWSHIP, UNITY, AND RECOVERY**

I am responsible, when anyone, anywhere, reaches out for help,  
 I want the hand of AA always to be there. And for that, I am responsible.

**SATURDAY  
 BREAKFAST  
 BUFFET**  
 Served from 8am to 10am.

**PASS IT ON CLUB**  
 6229 W.  
 Forest Home Ave  
 Milwaukee, WI 53220  
 414-541-6923

**BREAKFAST DATES**  
 January 8, 2011  
 February 12, 2011  
 March 12, 2011  
 April 9, 2011

**Menu**

- Scrambled Eggs
- Sausage
- Pancakes
- Fruit Cup
- Juice
- Milk

**Tickets sold at door  
 \$5.00**

**AA & AL- ANON  
COUPLE'S GROUP  
ANNUAL OPEN  
MEETING**

**SPEAKERS  
LYNDSEY A.  
(AL-ANON)  
&  
JENNY M.  
(AA)**

**St. Pius X  
2506 Wauwatosa Ave  
(76th St)  
in Wauwatosa**

**Enter from Wauwatosa Ave**

**Date:  
February 11, 2011**

**Doors Open:  
7:00pm**

**Speakers:  
7:30pm**

*35th Annual*

**BADGER** **Architect**  
**INTERGROUP!** **in**  
**iversity**

**SATURDAY**

**March 26, 2011**

Waukesha Expo Center  
(non-smoking facility)

**Speaker: Clancy I.  
from Los Angeles, CA**

Social Hour – 5:30 pm  
Dinner – 6:30 pm  
Speaker – 8:00 pm

*Dance to follow*

*Coffee & Soda Available*

**Tickets: \$24.00 each**

(PROCEEDS WILL BE SPLIT)  
*All Sales are Final – No Refunds*

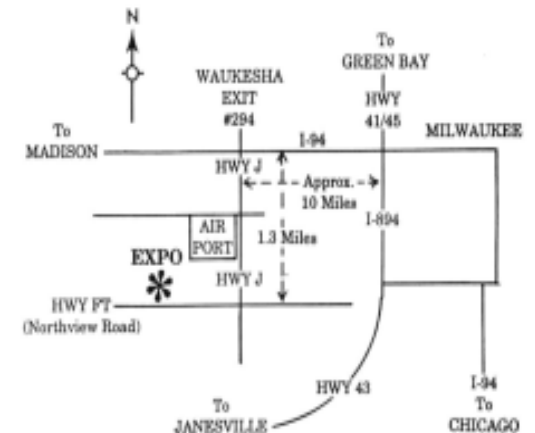

**TICKETS BY MAIL-IN ONLY.**

Payment must be received by **February 26, 2011.**

Tickets **will NOT** be sold at the door.  
THIS FLYER MAY BE REPRODUCED

**"We absolutely insist on enjoying life."**

MAIL TEAR-OFF SECTION TO: Christine Hutchinson 3929 S Troy Ave, St. Francis, WI 53235,  
262-227-4836

NAME: \_\_\_\_\_ PHONE: \_\_\_\_\_

ADDRESS: \_\_\_\_\_

NUMBER of TICKETS: \_\_\_\_\_ x \$24.00 each = AMOUNT ENCLOSED: \$ \_\_\_\_\_

\_\_\_\_\_ A.D.A. Accessible Seats Needed

Check Payable to: Badger Intergroup

**All Sales are Final!**

**THANK YOU!**